

Operation Manual

Black Light LED Lighting Fixtures

BB-30

BB-60



BLUEBAR[®]
BY WILDFIRE[®]

Table of Contents

Specifications	3
Introduction	4
Unpacking	4
Installation	4
Operation	5
Optional Accessories	5
Cleaning	5
Troubleshooting	5
Diagrams	6
Line View	6
Limited Warranty	7

Specifications

This unit is to be operated in accordance with the way it was designed and tested.
OPERATE IN DRY INDOOR LOCATIONS ONLY.
SUITABLE FOR SURFACE MOUNTING ONLY.

Housing:

Rolled steel

Finish:

Flat black powder coat

Mounting:

Two fully adjustable L brackets

Reflector:

Polished Everbrite Aluminum

Power Input:

BB-30 100-240VAC / 50-60Hz. / 0.3A Max

BB-60 100-240VAC / 50-60Hz. / 0.6A Max

Power Consumption:

BB-30 25W

BB-60 54W

Operating Temperature:

40° to 105° F

Operating Humidity:

0-95%

Light Source:

BB-30 Nine 3W, 400nm UV LED's

BB-60 Eighteen 3W, 400nm UV LED's

Lens:

Clear UVT Acrylic

Power Cord:

6' 16/3 SOW with male Edison

Circuit Protection:

2A Fuse

Dimensions:

BB-30 6.22"/15.79cm High x 3.07"/7.79cm Wide x 19.84"/50.39cm Long

BB-60 6.22"/15.79cm High x 3.07"/7.79cm Wide x 39.52"/100.38cm Long

Weight:

BB-30: 5.51 lbs./2.50kg.

BB-60: 9.92 lbs./4.50kg.

Standard Equipment:

Adjustable Mounting Brackets

Optional Accessories:

Floor Mount (147-006)

T-Bar Ceiling Mount (147-003)

Twenty Clamp (147-020)

Safety Cable (147-002)

Specifications subject to change without notice

Made in China

Introduction



Congratulations on your purchase of a BlueBar Series Fixture by Wildfire. These powerful and versatile black light LED lighting fixtures feature polished Everbrite reflectors and universal voltage operation. Each BlueBar Fixture is precision engineered to provide you with years of trouble free service. Please take a moment to read this manual thoroughly before attempting to operate this fixture. Improper set-up, use or servicing may cause damage to the fixture and void the unit's warranty.

Unpacking

Unpack the fixture and inspect it for any signs of physical damage. Report any damage to Wildfire or your local distributor immediately. Included with each unit should be the following items:

1. Two "L" shaped mounting brackets with two 11mm mounting holes for installing the fixture to any flat surface or attaching the optional Twenty Clamp or Floor Stand Kit.
2. Two rubber friction washers that are to be placed between the mounting brackets and the tabs on either end of the fixture allowing it to be held firmly in place upon tightening the locking knobs.
3. Two locking knobs with 8mm threaded studs that screw into the tabs on either end of the fixture.

Installation

The fixture can be installed on any flat surface or hung on a wall or ceiling using the included adjustable mounting brackets. Optional mounting hardware allows you to mount the fixture to a standard pipe truss, T-Bar drop ceiling or a floor stand set for footlight applications.

a) Flat surface installation

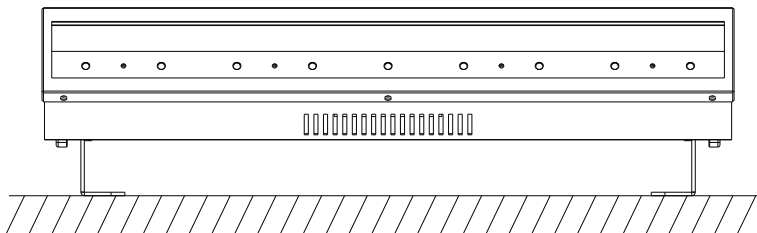

b) Hanging installation

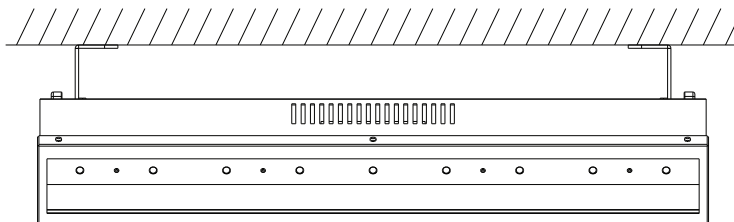

Operation



Plug the fixture into the appropriate power source that is properly grounded. If you are controlling the fixture with a lighting control board you will need to make sure it is plugged into a non-dim circuit. Do not at any time plug the fixture into a dimmable circuit, doing so will damage the fixture and void the warranty.

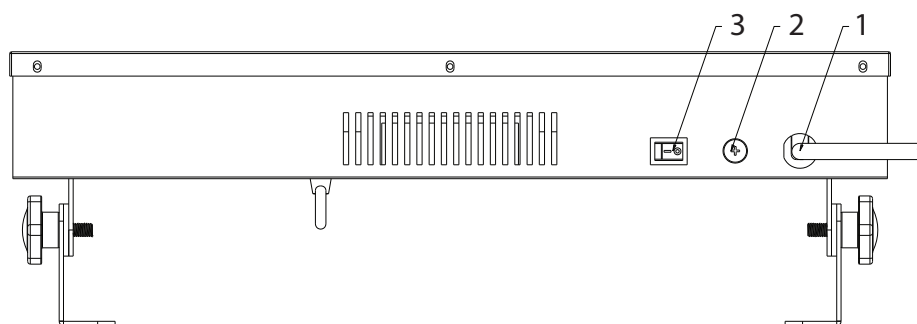

① Power Cable ② Fuse Holder ③ ON/OFF Switch

Optional Accessories

Twenty Clamp – These clamps when attached to both of the fixtures adjustable mounting brackets allows you to mount the fixture to a standard 2” pipe truss. Contact Wildfire or your local distributor for pricing.

Safety Cable- This cable is to be used when installing the fixture on a pipe truss with the Twenty Clamps. It attaches to the metal ring on the rear of the fixture securing it from falling if the clamp is not tightened properly. Contact Wildfire or your local distributor for pricing.

Floor Mount Kit- This aluminum stand set enables you to mount your fixture on the floor for footlight applications. Contact Wildfire or your local distributor for pricing.

T-Bar Ceiling Mount- These brackets enable you to mount your Effects Master fixture to the t-bars in a standard drop ceiling. Contact Wildfire or your local distributor for pricing.

Cleaning

At no time should any cleaning chemicals or abrasives be used to clean any part of the unit. For normal cleaning, a dry soft cloth should be used to wipe any surface free from dust and light dirt. Always unplug the unit before cleaning.



Troubleshooting

If the fixture will not light, check to make sure there is power to the fixture. check to make sure the fuse is not blown and replace if necessary. Do not attempt to dismantle the fixture doing so will void the warranty. Other than the fuse, there are no other user serviceable parts in the fixture.

Diagrams

Line View

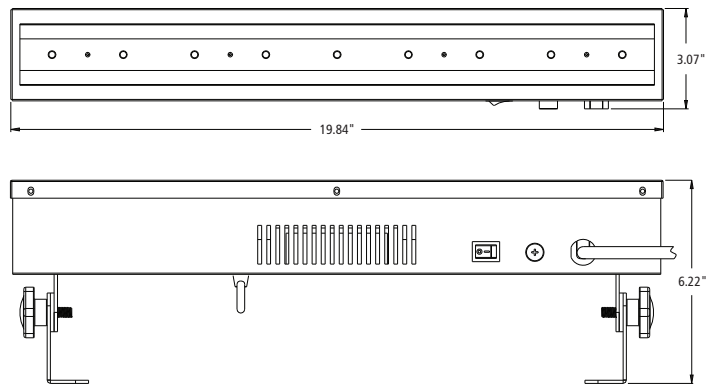
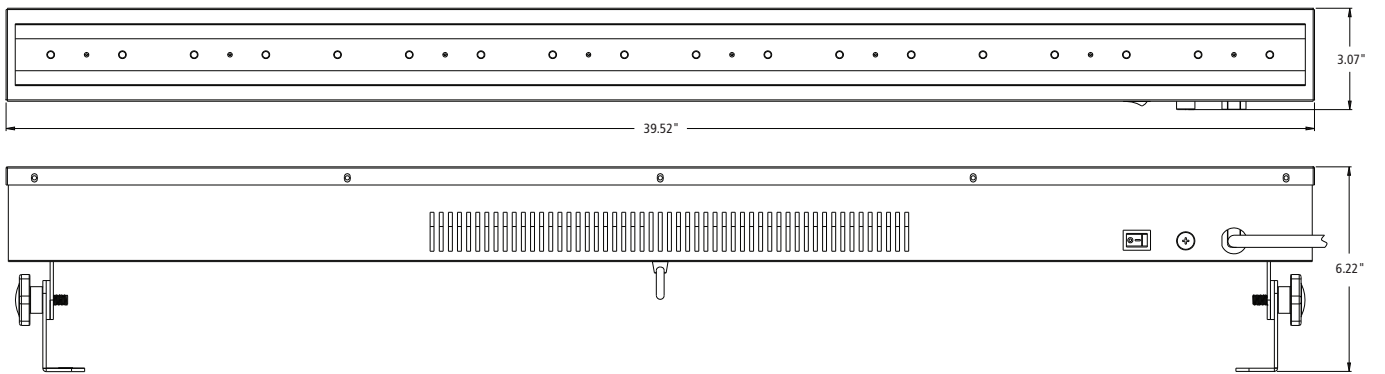

Wildfire, Inc. One Year Limited Warranty

Wildfire, Inc. warrants to the original owner or retail customer, that for a period of one year from the date of delivery of any Wildfire Fixture; whether used in a portable or permanent installation, such fixtures will be free from defects in material and workmanship under normal use and conditions.

Warranty does not cover any product or part of a product that has been subjected to accident, negligence, alteration, abuse or misuse and excludes any accessories or parts not supplied by Wildfire. Warranty does not cover expendable parts such as fuses, lamps, glass or any components warranted directly to the owner by the original manufacturer. This warranty does not extend to products not manufactured by Wildfire.

Wildfire's responsibility under this warranty shall be to repair or replace at Wildfire's discretion such parts as determined to be defective upon Wildfire's inspection. Wildfire will not assume any responsibility for any labor expended or materials used to repair any equipment without Wildfire's prior written authorization.

Wildfire, Inc. shall not be responsible for any incidental, general or consequential damages to property, damage for loss of use, time profits or income, or any other charges.

The owners' obligation during the warranty period is to notify Wildfire of any suspected defect, to obtain a return authorization number, and to return the product freight and insurance prepaid to the following address:

**Wildfire Service, 2908 Oregon Court Suite G1, Torrance, CA 90503
(800) 937-8065 (310) 755-6780**

Collect shipments for freight allowances or shipments without return authorization numbers will not be accepted.

THIS WARRANTY IS EXPRESSLY IN LIEU OF ANY AND ALL OTHER WARRANTIES EXPRESSED OR IMPLIED INCLUDING THE WARRANTIES OF MERCHANTABILITY AND FITNESS FOR A PARTICULAR PURPOSE AND ALL OTHER OBLIGATIONS AND LIABILITIES ON WILDFIRE'S PART. THERE ARE NO WARRANTIES WHICH EXTEND BEYOND THE DESCRIPTION ON THE FACE HEREOF. THE OWNER ACKNOWLEDGES THAT NO OTHER REPRESENTATIONS WERE MADE TO HIM WITH RESPECT TO THE QUALITY AND FUNCTION OF THE GOODS SOLD.

This written warranty is intended as a complete and exclusive statement of the terms thereof. Prior dealings or trade usage shall not be relevant to modify, explain or vary this warranty. Acceptance of, or acquiescing in, a course of performance under this warranty shall not modify the meaning of their agreement even though either party has knowledge of the performance and a chance to object.

This limited warranty gives you specific legal rights and you may also have other rights which vary from state to state. If any action or preceding results from this warranty, the prevailing party will be entitled to all costs and attorney fees incurred in defending or prosecuting such actions.



2908 Oregon Ct. Suite G1, Torrance, CA 90503
P: 310.755.6780 800.937.8065 F: 310.755.6781
wildfirelighting.com mail@wildfirelighting.com

© 2017 Wildfire, Inc.